

# SCS-SP/SSUV SEAL FOR AGITATED NUTSCHE FILTERS

- DUAL BALANCED, DRY / WET RUNNING DOUBLE SEALS
- STEAM STERILIZABLE. GMP DESIGN ON REQUEST
- NON CONTACTING DRY GAS SEALS ON REQUEST
- SOLID ANTI-FRICTION LINEAR BEARINGS INTEGRAL WITH THE SLEEVE
- HEAVY DUTY STURDY DESIGN WITH TWO TAPER ROLLER BEARINGS.
- SPECIAL GRADE HARD FACES, FREE FROM PARTICLE SHREDDING ON REQUEST
- BELLOW ASSEMBLY WITH LONG FATIGUE LIFE

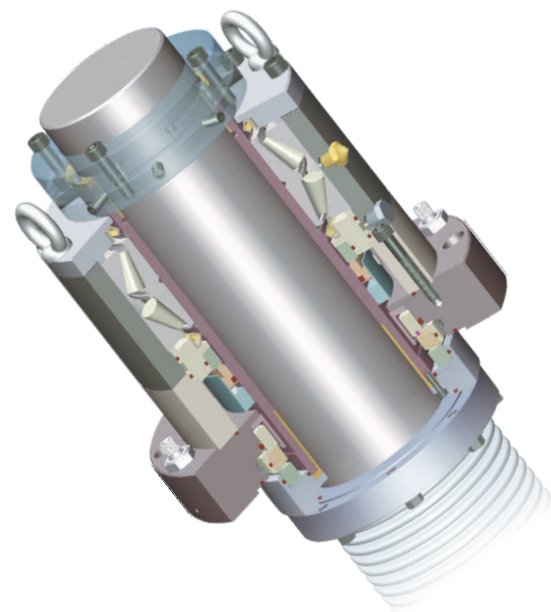

HI-FAB is one of the largest manufacturer of ANF seals. HI-FAB design is innovative and departs from other conventional designs for better seal life. These seals are continuously in operation for more than five years at many plants in India, Europe and America. HI-FAB ANF seals have been successfully used on horizontal reactors and mixers with expanding shafts.

### APPLICATIONS :

- AGITATED NUTSCHE FILTERS & DRYERS
- ROTARY VACUUM PADDLE DRYERS
- HORIZONTAL REACTORS WITH EXPANDING SHAFTS

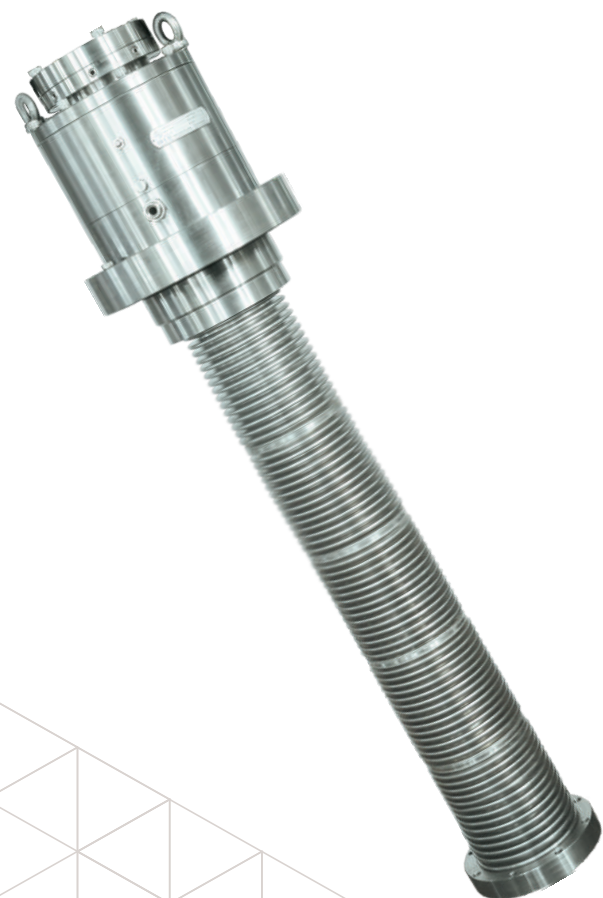

### INSTALLATION DIMENSIONS

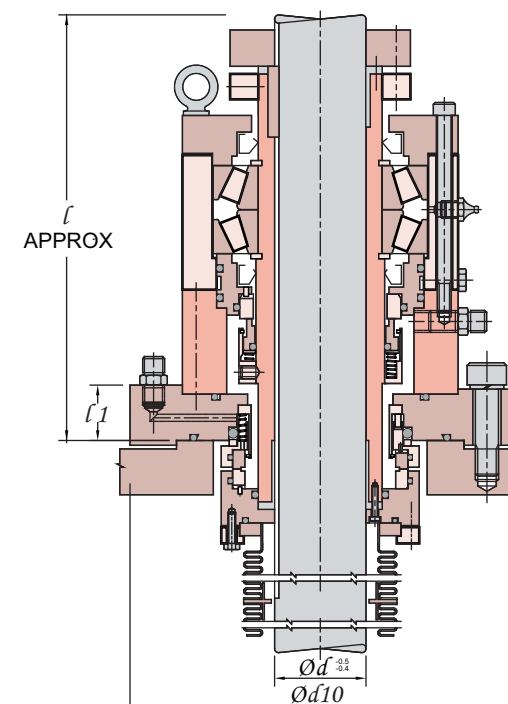

SIZE CODE	d	d10	l	l1
0600	60.0	200.0	220.0	30.0
0800	80.0	247.0	290.0	30.0
1000	100.0	282.0	320.0	33.0
1100	110.0	302.0	325.0	33.0
1200	120.0	312.0	330.0	33.0
1300	130.0	332.0	335.0	33.0
1400	140.0	352.0	340.0	33.0
1500	150.0	372.0	360.0	33.0
1600	160.0	402.0	390.0	35.0
1700	170.0	435.0	390.0	35.0
1800	180.0	435.0	390.0	35.0
2000	200.0	470.0	410.0	50.0

Dimensions for higher sizes available on request

### LIMITING PARAMETERS

PRESSURE	TEMPERATURE	SPEED
FULL VACUUM TO 7 BAR	- 80° C TO 200° C*	1 m/sec

\* For higher temperatures consult HI-FAB

### MATERIALS

METAL PARTS	SEAL FACES	ELASTOMERS
SS316 / HAST-C 22 HAST-C 276	INBOARD: SIC / SIC OUTBOARD: CARBON / SIC	VITON, PTFE, STV, SILICON FFKM, AFLAS, EPR

### DESIGN VARIATIONS

